

MULTIFUNCTION
HYDRAULIC BANK
MOD09
INSTALLER AND USER MANUAL

CE marked product in accordance with 89/336/EEC e 89/392/EEC directives

INDEX

INDEX.....	2
1. INTRODUCTION.....	3
1.1 Product description.....	3
1.2 Working description.....	3
1.3 Typical applications.....	3
2. INSTALLATION.....	4
2.1 Preface.....	4
2.2 Mechanical installation.....	4
2.3 Hydraulic connections.....	5
2.4 Electrical connections.....	6
2.5 Rules for a correct and safe installation.....	7
3. MAINTENANCE.....	7
4. TROUBLE-SHOOTING.....	8
5. SCRAPPING.....	8
6. SPARE PARTS LIST.....	9
6.1 After sale service.....	10
6.2 Warranty.....	10
7. TECHNICAL DATA SHEET (single section).....	11
MANUFACTURER DECLARATION.....	12



The paragraphs marked with this symbol contain information to follow carefully in order to avoid situations of potential danger for people or things.



This symbol appears in the handbook in order to signal paragraphs containing information to follow scrupulously in order to guarantee the correct operation and a long operating life of the equipment.

This manual must be always joined to the hydraulic bank for adjusting, repairing and maintenance works at equipped workshops. Store it accurately for consultations in case of technical troubles or further changes to electric and hydraulic system.

No part of this publication may be reproduced without the prior written permission.

Version 1.0

1. INTRODUCTION

1.1 Product description

Dear Customer, thank you to have chosen a ATS product.

The hydraulic bank described in this manual is an electrohydraulic system that coupled with a manual hydraulic distributor allows itself to be controlled remotely. The bank is made up of a manifold with mounted on as much sections (modules) as the movements to activate. All the modules are identical and they are fixed to the manifold with four screws stay. Each module works as stand alone.

Each module is made up of a hydraulic cylinder commanded by two proportional valves with mechanical feedback (look figure 1).

The coupling of the hydraulic bank pistons to the manual distributor, already mounted on the machine, is done by brackets to screw on the dual control rods which have to be coupled with the forks mounted on each piston.

It is possible to connect the forks to a different leverage system as long as is guaranteed, with right slots, an enough play to prevent stress in different direction than the axial one.

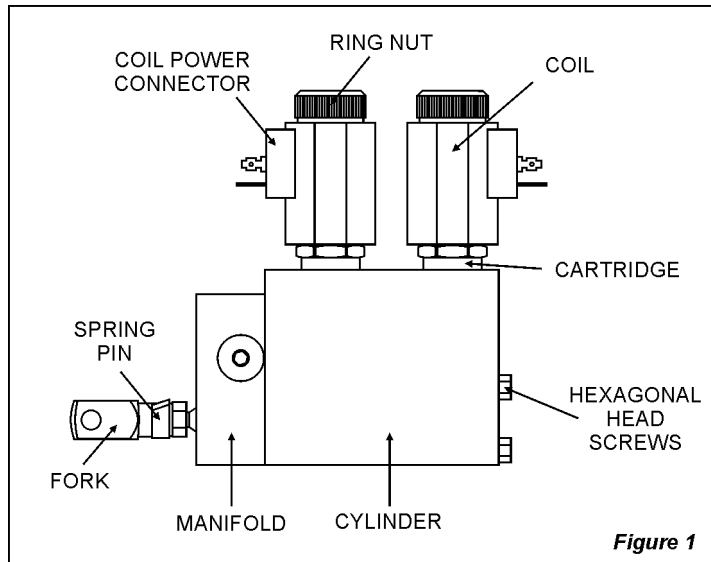

1.2 Working description

Each module of hydraulic bank has to push or pull the lever of the linked manual distributor. To make his work the hydraulic bank must be connected to an hydraulic circuit and to an electronic control system with PWM current output.

The movement of the piston, and the opening of the linked function of the manual distributor, is proportional to the value of the current supplied to one of the proportional solenoids (to be powered up one each time).

When the hydraulic circuit is under pressure the piston will move in a direction or in the other one depending on which solenoid is powered up. The "I_{min}" current is the required value to start to move the piston, the "I_{max}" current is the required value to move the piston to the full stroke. For other current values, between "I_{min}" and "I_{max}", the piston will stop in an intermediate position proportional to the current value.

When the current of the proportional solenoid is missed the piston will come back to the central position by only the returning action of the internal and the manual distributor springs.

1.3 Typical applications

This type of hydraulic bank can be used to remotely control manual hydraulic distributors with a lower stroke than the module stroke (look technical data sheet); it is designed to be coupled to the dual control rods.

It is not allowed to use this block in systems with climatic, electric, hydraulic and mechanical specifications different from the ones listed in the technical data sheet.

The system cannot be used in environment that needs explosion-proof specifications.

2. INSTALLATION

2.1 Preface

The installation of the hydraulic bank must be done by prepared technicians and by appropriately equipped workshops following what is described in this manual.

Check the packaging state after received the hydraulic bank and verify the inside material state. If it appears damaged by shocks or drops happened during the transport please check all the component parts. If you suspect the presence of problems keep in touch with the manufacturer before the installation on the vehicle to choose between the change or the reparation of the damaged parts.



The hydraulic modules bank is heavy and must be handled with care, paying attention to do not shocking it or putting it violently on the ground. Little imperceptible dents could compromise the good working. It could be greasy due to the oil left inside during the testing phase so it is essential to wear gloves and working clothes when you handle it.



The installation of the hydraulic bank is not particularly difficult, but, to guarantee a good working system, we recommend to follow carefully what is described afterwards in this manual. Install all the safety systems required and do not exclude the already existing ones following respective manufacturer's instructions.

2.2 Mechanical installation

Locate on the crane the position where you'll mount the hydraulic bank.



The rules used to choose the right position are as follows:

- The manifold must be mounted mostly in horizontal position. Other positions can be used but they are not recommended because it makes difficult to bleed air from the hydraulic circuit.
- The manifold must be fixed to the crane frame and not to the truck frame. The bearing must not bend too much when the pistons work on the dual control rods.
- If the crane has an hydraulic overload system (used to bring forcedly the distributor levers in the zero position when you exceed the loading capacity) you have to verify the rods are sturdy enough to avoid deformations.
- It must be possible to reach the screws that fix the brackets on the dual control rods (to verify the clamping).
- In the back of the hydraulic bank must exist the necessary space to unscrew the stay bolts and and unthread the module (to replace it).
- The connectors of the solenoids must be reached simply (it is easier to verify when a problem occurs).

In case that the distance between centres of the rods is not the same of the modules, it is anyway possible to mount the system paying attention to place the bank centred with the rods; you have to match the position of the central modules with the central rods to distribute the difference of distance between centres of all modules. The maximum value of the two axis distance is about 20 mm (look figure 2).

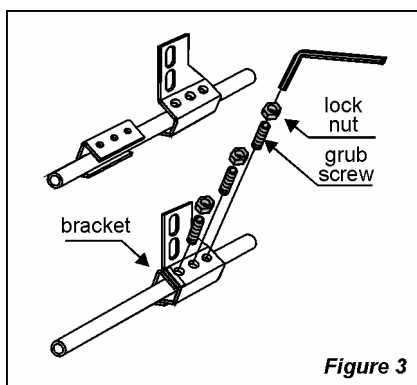
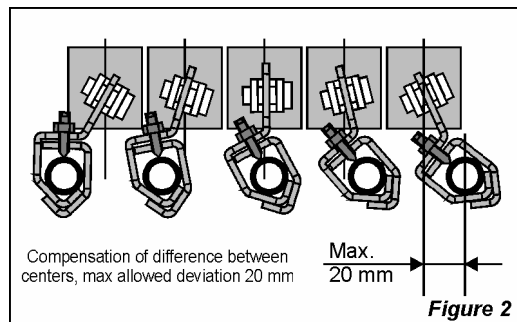

Figure 3



Be sure that the pistons of the bank are all aligned to the middle of their stroke (zero position), mount the brackets on the rods without tighten the screws, link the piston forks to the brackets and block them with the spring pins.

Tighten the screws, locking all them at least two times and after this tighten the lock nuts (look figure 3).

The coupling between the pistons and the rods to move must have less play possible in the movement direction (axial) to use all the useful stroke of the pistons without death zones. On the other hand, it is required the presence of certain play in the other direction (transversal). The play is obtained by the brackets slots or using the opening of the fork.

The pistons must be stressed only in the axial direction. A transversal loading of the pistons may block them and quickly wear out the gaskets.

The distributor levers, after the assembly of the modules and with themselves switched off, must remain aligned. Pulling the distributor levers by hand, the rods must move freely without show hardening.

When you release the levers they must return to the centre immediately unhesitatingly. If the levers return to the centre slowly it can be necessary substitute the distributor recall springs with a more strong type (contact the manufacturer of the distributor).

If you want to connect the hydraulic bank directly on the rear exit of the distributor, don't couple the forks "front to front" but use always a bracket and connect the fork to a slot (look example figure 4).

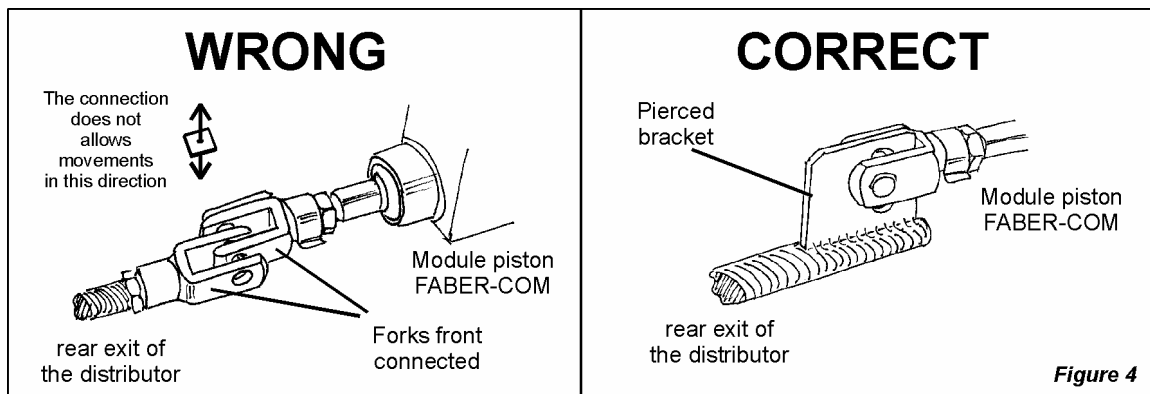

2.3 Hydraulic connections

The multifunction bank must be hydraulically supplied with a low pressure (look data sheet). The hydraulic connections can be obtained from the main crane hydraulic circuit using a counter-pressure block or from an independent hydraulic pump unit (suggested).

In both cases it is required to install a filter of a nominal value of at least 10 micron.

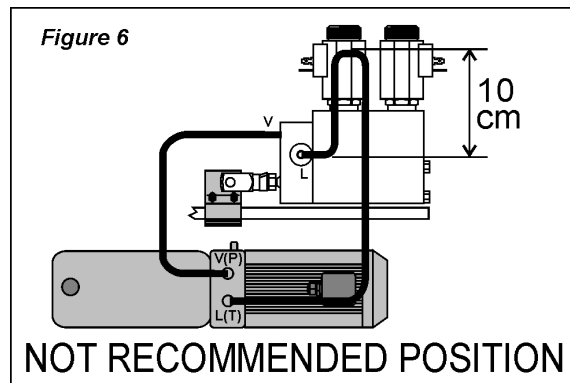
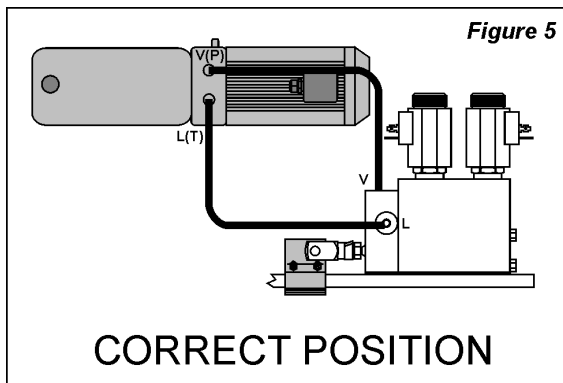

If you use the hydraulic pump unit, it has to be mounted in a higher position compared to the hydraulic bank. If this is not possible, leave an exhaust pipe of at least 10 cm upside before the downward curve to the oil tank; this to avoid the entrance of air from the exhaust hole in the hydraulic circuit when you use the distributor manually (look figure 5 and 6).

The oil inlet for the hydraulic bank (delivery) is marked with the letter "V", the oil outlet (exhaust) is marked with the letter "L" (look figure 7).

Pay attention when you make the hydraulic connections. If you exchange the inlet with the outlet the piston movement becomes uncontrollable.



It is not possible to connect the inlet and the outlet pipe into the same manifold header. It is suggested to use the 1/4" connectors on the front side. The pipes used for the links must be suitable for this type of use and must carry the current pressures.



If you mount a counter pressure block on the main crane circuit, be sure to connect directly the exhaust to the oil tank without filters or other links (look figure 8 and 9).

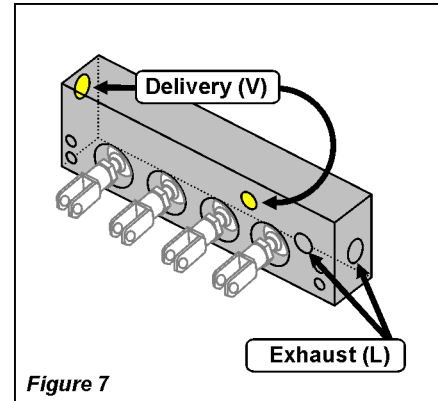
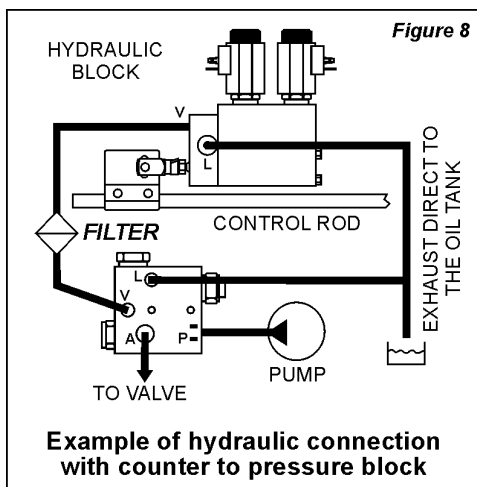
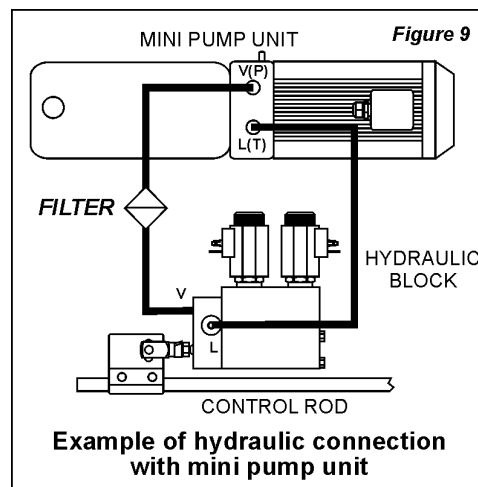

Figure 7



Example of hydraulic connection with counter to pressure block



Example of hydraulic connection with mini pump unit



If there is air inside the circuit the piston does not move itself smoothly (it does not move or it bumps). After you have done the hydraulic connections, supply the system and make some manoeuvres with all pistons to guarantee the oil fulfil of the cylinders and the exit of the air already inside the hydraulic circuit.

2.4 Electrical connections

The proportional solenoids have a DIN43650 connector. The winding is connected between the connector pole 1 and 2. The ground pole is not used. When it is powered the solenoid A the piston will move inside, when it is powered the solenoid B the piston will move outside (look figure 10).

The piston stroke is determined by the value of current absorbed by the solenoid. The piston moves itself from the zero position to the longest position outside or inside when the solenoid absorbs the greatest current value (look data sheet).

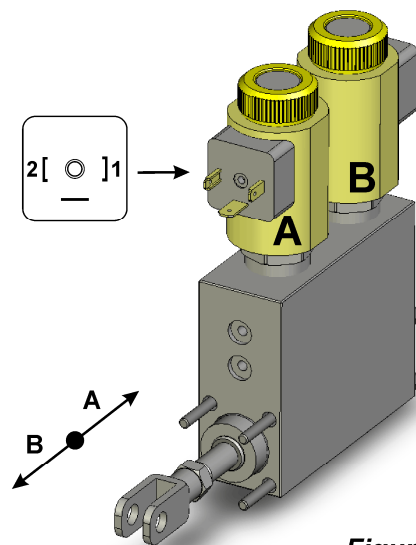

Figure 10

2.5 Rules for a correct and safe installation

- a) Do not make welding with the hydraulic bank mounted. Dismount the bank also when you have to weld on the rods or on the bearing.
- b) If it is possible, orient the solenoid power cables downward so the rain do not reach the connector.
- c) Fix carefully the connectors verifying the correct position of the gaskets. Use only the supplied screws or screws with the same length. If you fasten too much the screws the connectors can be damaged.
- d) Mount a steel cover sheet (or other material) that covers the zone of the connectors in order to avoid that the rain goes directly into the connectors (look figure 11).
- e) The cover must be easily removable for the operations of inspection and eventual maintenance on hydraulic modules.
- f) The cover must leave enough space for the circulation of the air necessary for the cooling of the modules.
- g) Do not wash with jets under pressure and do not dip the equipment in water.
- h) Avoid the contact with corrosive solvents.
- i) Do not execute operations with the bank electrically supplied or under pressure.
- j) Use exclusively mineral oil avoiding vegetable oils or other mixtures. The use of not suitable oil in the system damages the gaskets.
- k) It is necessary to mount on the main hydraulic circuit of the crane a safety dump valve (**BYPASS**) normally opened (in derivation between the pump delivery and the exhaust) that maintains without pressure the system when no manoeuvre is executed. Every time that a solenoid of the hydraulic bank is supplied (in order to move the distributor levers), also the safety valve has to be supplied, that closing itself will send the main system under pressure. Such valve has to be supplied also when someone manually use the hydraulic distributor of the crane.

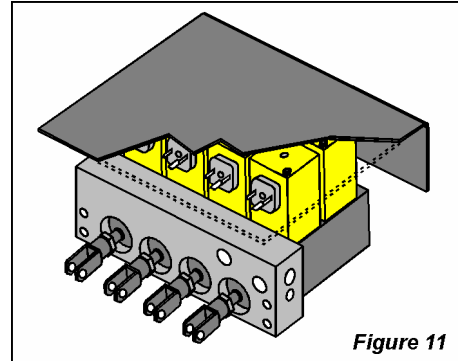
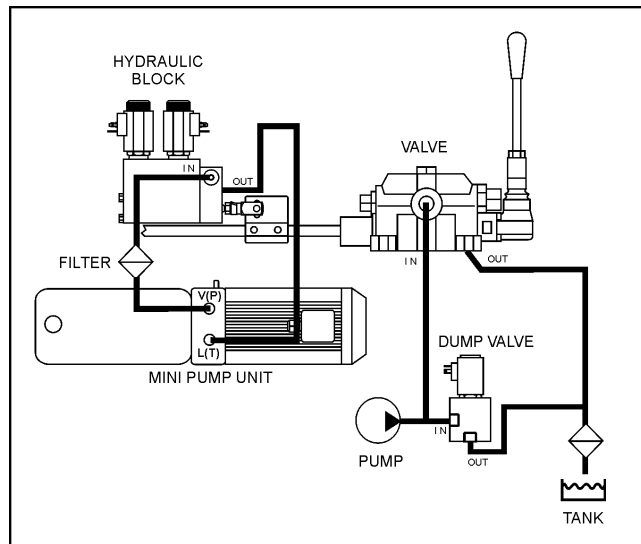

Figure 11



The manufacturer does not answer for the damages caused to the system and from the system in case it has not been respected these elementary norms of emergency.

3. MAINTENANCE

To guarantee a good work and in safety conditions of the hydraulic bank the user must do a periodical check on the bank itself and on the other accessories installed on the system. You have to verify:

BEFORE EACH WORK SESSION:

- **The perfect running of the safety valve:** with the system under pressure but without electric power (valve not supplied), moving a manual distributor lever, the crane must not move.

PERIODICALLY (based on the effective use):

- The perfect running of the hydraulic bank and of the installed accessories on the system.
- The state of the oil filter. The filter must be cleaned and, if it is very dirty, it must be replaced.
- The oil level of the hydraulic pump unit (if present).
- The state of the electrical wires connected to the hydraulic bank.
- The presence of rust.



4. TROUBLE-SHOOTING

Here we describe the most common cases of bad working. Before contact the after sale service, please check if the breakdown can be solved following the suggestions and the executing tests indicated in the following table:

Breakdowns	Possible causes and remedies
Supplying any solenoid of the hydraulic bank the pistons do not move or they are very slow to start to move.	<u>Very low pressure or the oil does not arrive to the modules</u> ; verify the oil pressure on the delivery pipe with a gauge (it must be at least 15 BAR, max. 30 BAR) or verify that disconnecting the pipe physically the oil comes out (when someone makes a manoeuvre). If the oil comes out slowly, check the state of the oil and of the delivery filter. Check that the exhaust pipe of the hydraulic modules is connected directly to the oil tank, without filters or too much long pipes.
It is impossible to regulate the proportionality of one or more manoeuvres.	<u>The cartridge is dirty</u> ; the component parts of the cartridge associated to the irregular manoeuvre are obstructed from impurity that slow down the operation. Dismount and clean up the cartridge in order to solve the problem and install a filter on the delivery pipe to avoid again the same problem.
A lever of the distributor remains blocked on maximum opening on one side or on the other side.	Uncouple the fork from the bracket on the dual control rod and verify that the defect does not come from the distributor. <u>Impurity in the hydraulic circuit</u> ; dismount and clean up the module cartridges or change the whole module and mount a delivery filter.
The defect is not written in this list.	Identify the type of the problem: electric or hydraulic. Disconnect the connector on the module that shows the defect; if the defect exists again then there is an hydraulic problem, if the defect disappears there is an electrical problem. Try to exchange the connector of a working module with ones of a defective module; if the defect moves the cause is not in the module.

5. SCRAPPING

In case of shipment of the hydraulic bank to the manufacturer for a checking, use possibly the original packaging or one that offers a good protection against external things and between the same parts inside the box.

If, for change or scrapping, it is decided to take apart the equipment from the truck, take care of the oil that come out from the hydraulic circuit and get rid of it, with the other components, following the current norms, in an authorised centre.

6. SPARE PARTS LIST

The only available spare parts for the hydraulic bank are listed in the following table. If are damaged other parts please contact the supplier.

NR	DESCRIPTION	CODE
1	Coil	A2000710040 (12v) A2000710041 (24v)
2	Female connector DIN 43650 (2p+T)	A2001300020
3	Cartridge (with O-Rings)	A5000310010
4	Spring	A3001750040
5	Manifold (functions/interaxis)	PIP4409 (4F/40) PIP6409 (6F/40) PIP8409 (8F/40) PIP4469 (4F/46) PIP6469 (6F/46) PIP8469 (8F/46) PIP4509 (4F/50) PIP6509 (6F/50)
6	Connecting rod M5x115	A3003800040
7	Cylinder	A5000810020
8	Piston (with O-Rings)	A5000800030
9	Fork	A3001100010
10	Spring pin	A3000400010
11	Lock nut M8	A3000700061
12	Staffa a 3 grani	PSAI3
*	Gaskets kit (includes all O-Rings of the module)	A5000430010
*	Complete module 12V (with 43650 connectors and connecting rods)	CIAP91C
*	Complete module 24V (with 43650 connectors and connecting rods)	CIAP92C
*	Complete module 12V (without 43650 connectors and connecting rods)	CIAP91R
*	Complete module 24V (without 43650 connectors and connecting rods)	CIAP92R
*	Cap for closing unused holes of the manifold	PTCI9

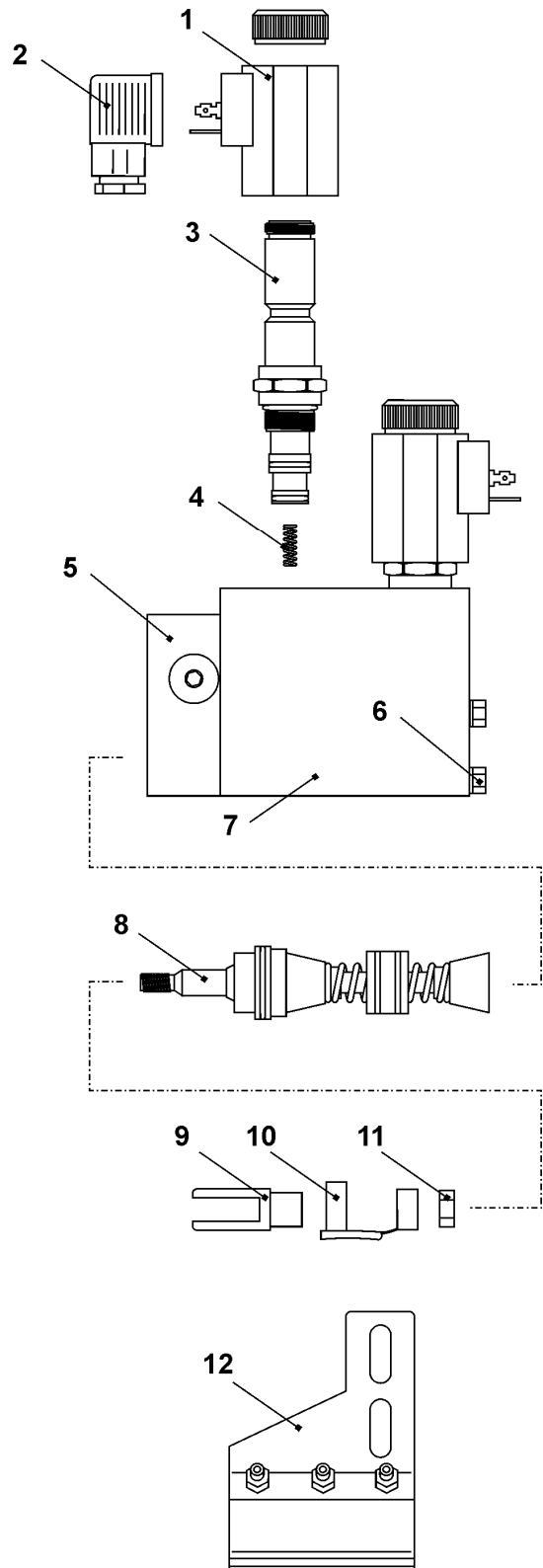

6.1 After sale service

If you cannot solve the problem also with the help of the examples included in this manual is necessary to call **exclusively** to the installer. This one can contact our after sale service providing us the following information.

- Type of system
- Serial number of the system (look chapter 5)
- Possible special characteristics of the system (look chapter 5)
- Accurate description of the problem, in which conditions the problem show itself and when it's started to show.

The manufacturer after sales service can be contacted by telephone, by internet or by fax and **only the installers can exclusively use it.**

The telephone after sale service is active every working day in office timetable.

Only a competent technician, after he tried to solve the problem by telephone and after he has estimated the type of the defect, can authorise the shipment for the repair or the eventual shipment of a replacement part.

We will accept rendered material only if it has been authorised in advance and it has been shipped "CARRIAGE FREE" (if not agreed in a different way). The repaired material will be sent back "CARRIAGE FORWARD".

The rendered material must be sent comprehensive of all the component parts (screws, O.R, brackets, forks, lock nuts, etc).

In case of technician exit for a repair to the user, it will be always debited, beyond to a fixed right of call, expenses of travel based on the current kilometric rates and the time used for the repair.

6.2 Warranty

The manufacturer guarantees the good working of the equipment of own production for a period of 12 (twelve) months from the date of purchase certified by the invoice at the specified conditions below.

- a) The warranty includes, of course, the change or the free repair of the parts of the equipment that have production defects and not damages due to bad maintenance or improper use of the equipment.
- b) The manufacturer can decide unquestionably on any issue about complaints and defects.
- c) In the hypothesis of improper use or bad maintenance and/or in case of violation of the equipment from users not authorised by manufacturer, the customer will loose all rights of assistance under warranty.
- d) The manufacturer has no responsibility for eventual damages that, directly or indirectly, could arrive from people or things for the missed observance of all instructions indicated on the "manual" and, especially, referring to the installation, safety, use and maintenance indications. Moreover this warranty does not include compensation for the equipment inefficiency or stop periods of the machines.
- e) The equipment will be repaired in FABER-COM s.r.l. or in the nearest After Sale Authorised Centre. Costs and risks of transport from and to the assistance centre will be at customer charge. Please consider that all costs referring to equipment repair and/or change, as for instance (but not only this) FABER-COM s.r.l. people travelling expenses, will be completely at customer charge.
- f) Every defective piece replaced not under warranty will become ownership of the customer.
- g) Every defective piece replaced under warranty will become ownership of the manufacturer.
- h) For assistance or requests without a well precise fault and for installation or explanation of system use rules, already explained in the "manual", all costs are at buyer charge.
- i) If demanded, for all repaired components, will be given a copy of the technical relation with problem description, and added or replaced materials. If the repair is not possible or could be more expensive than the sale price of the new component, the sales department will contact the customer for a new offer and the defective material will be sent back without repair it.

7. TECHNICAL DATA SHEET (single section)

Working power supply	12V or 24V version
Working PWM current	800 ÷ 1800 mA (12V) 350 ÷ 1000 mA (24V)
Working frequency	120 Hz
Feedback	Mechanical
Working room temperature	-20 ÷ +60 °C
Type of fluid	Mineral oil 10 ÷ 200 cSt
Max. working pressure	30 bar
Max. thrust	1300 N (at 30 bar)
Mechanical stroke	±13 mm
Weight	1.6 kg approx.
Overall dimensions (mm)	200 (W) x 160 (H) x 35 (D)
Blow-by (max.)	100 cc/minute
Connections	G1/4" BSPP

MANIFOLD TYPE	A (mm)	B (mm)	C (mm)
4 functions	40	182	200
	46	200	218
	50	212	230
6 functions	40	262	280
	46	292	310
	50	312	330
8 functions	40	342	360
	46	384	402

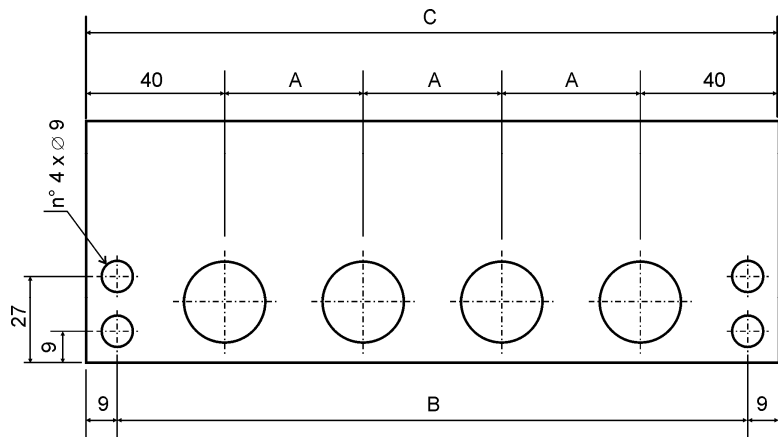

Serial number:..... N° functions:

Particular specifications:

.....

.....

.....

Test date:..... Tested by:.....
